



**Eclipse  
Combustion**

# RatioMatic Burners

Model RM050

Version 3.10

## Main Specifications - RM050

PARAMETER		SPECIFICATIONS			
		English		Metric	
		Capacity @ Chamber Pressure			
		BTU/hr	@ "w.c.	kW	@ mbar
Maximum input	60 Hz packaged blower	650,000	-5.0	190	-12.4
		600,000	-3.0	176	-7.5
		500,000	0.0	147	0.0
		460,000	1.0	135	2.5
		420,000	2.0	123	5.0
	50 Hz packaged blower	660,000	-5.0	193	-12.4
		610,000	-3.0	179	-7.5
		520,000	0.0	152	0.0
		490,000	1.0	144	2.5
		450,000	2.0	132	5.0
Note: Contact factory for varying chamber pressures or pressures outside the range: -5.0 to 2.0" w.c. (-12,4 to 5,0 mbar)					
Minimum input	with high turndown ratio regulator	BTU/hr		kW	
	with standard ratio regulator	20,000		6	
		30,000		9	
Main gas inlet pressure • fuel pressure at ratio regulator inlet		10 to 20 "w.c.		25 to 50 mbar	
High fire flame length • measured from the outlet end of the combustor		24 in		600 mm	
Maximum chamber temperature	Alloy tube SiC tube	°F		°C	
		1500		815	
		1900		1038	
Flame detection		Flame rod or UV scanner			
Fuel		Natural Gas, Propane or Butane. For any other mixed gas, contact Eclipse Combustion for orifice sizing			

- All information is based on laboratory testing. Different chamber size and conditions will affect the data.
- Maximum inputs are given for the standard combustion air blower without an air filter.
- All inputs based upon gross calorific values and standard conditions; 1 atmosphere, 70° F ( 21°C).
- Eclipse reserves the right to change the construction and/or configuration of our products at any time without being obliged to adjust earlier supplies accordingly.

# Performance Graphs

## RatioMatic RM050

### Control & Operation Zone

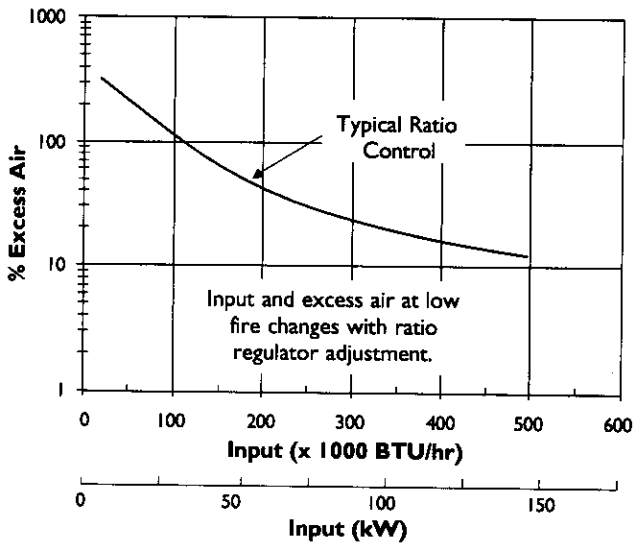

### NOx Emission Data

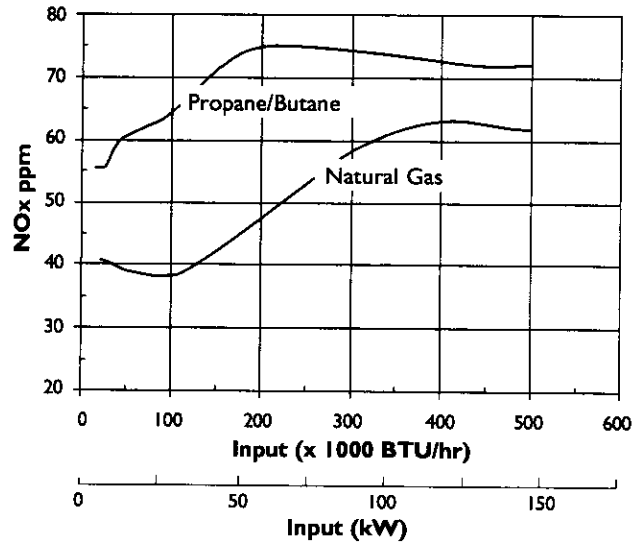

NOx emission data is given for:

- Ambient combustion air ~70 F (20 C)
- Less than 700 F (370 C) firing chamber
- Minimal process air velocity
- Low fire input adjusted to 20,000 BTU/hr (6kW)
- ppm volume, dry @ 3% O<sub>2</sub>
- Neutral chamber pressure

Emissions are influenced by:

- Chamber conditions
- Fuel type
- Firing rate
- Ratio regulator adjustment
- Combustion air temperature

CO emission is largely influenced by chamber conditions. Contact your local Eclipse Combustion representative for an estimate of CO emission on your application

### Fuel Orifice ΔP vs. Input

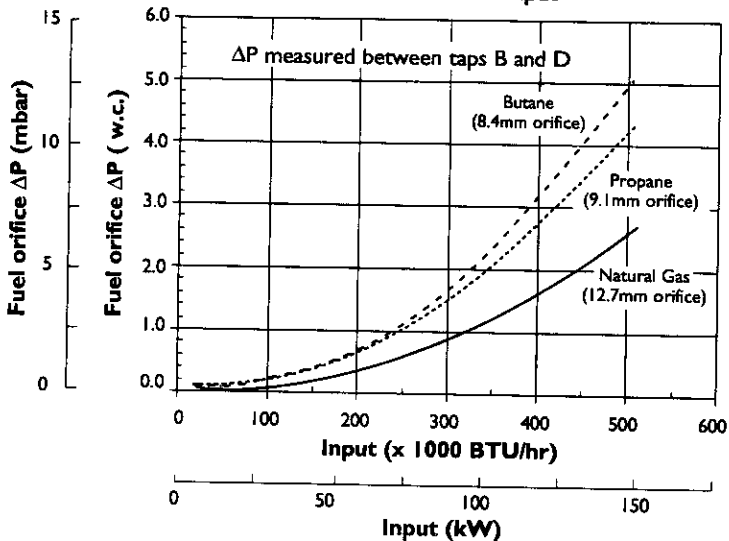

### Air ΔP vs. Air Flow

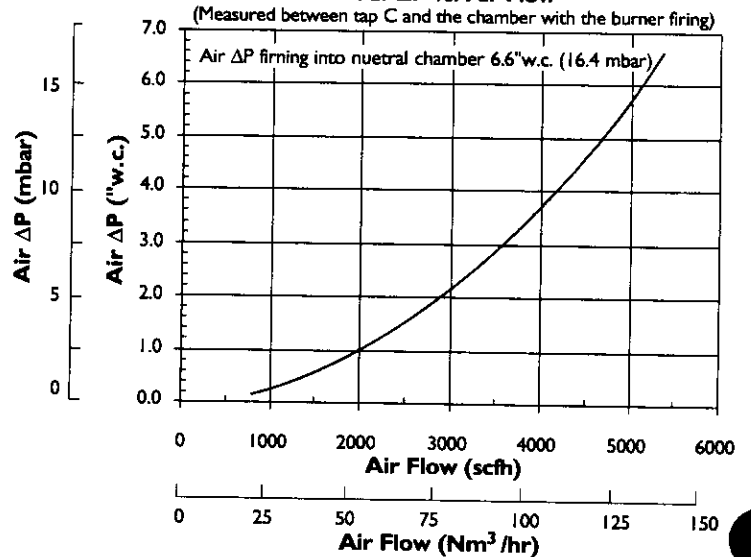

## Dimensions-RM050

Dimensions in mm (in)

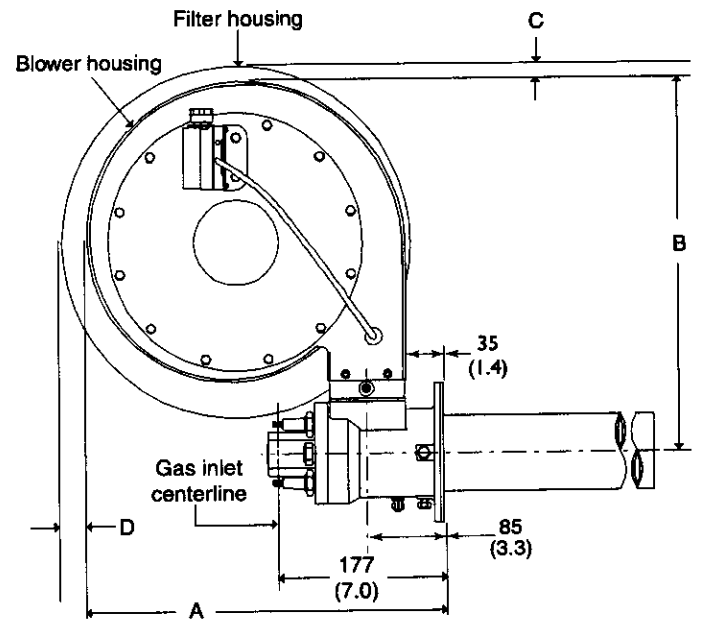
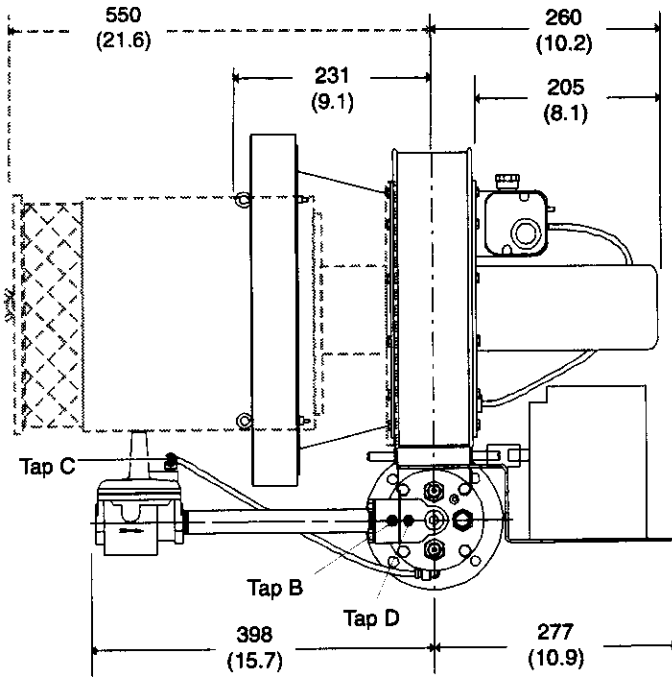

	A	B	C	D
50 Hz	470 (18.5)	500 (19.7)	n/a	n/a
60 Hz	410 (16.1)	430 (16.9)	20 (0.8)	30 (1.2)

Weights	lb	kg
Packaged burner	58	27
Filter silencer	21	10

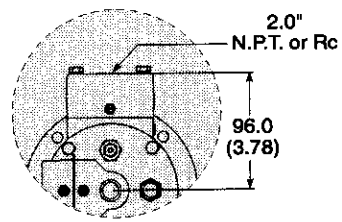

Less Blower Option

## Combustor types

Alloy tube

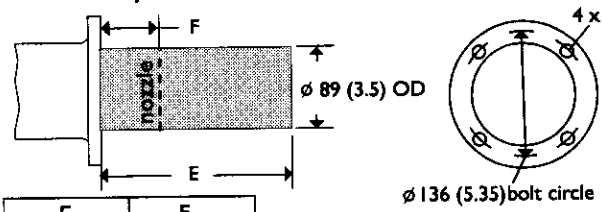

E	F
240 (9.4)	80 (3.1)
314 (12.4)	150 (5.9)
394 (15.5)	235 (9.3)

SiC tube

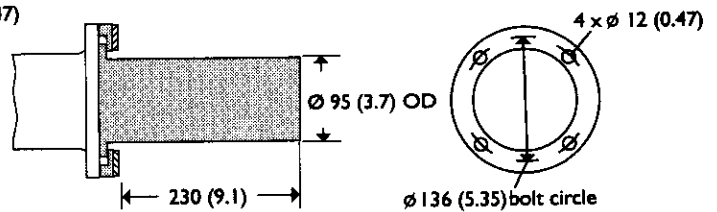

## Burner configuration

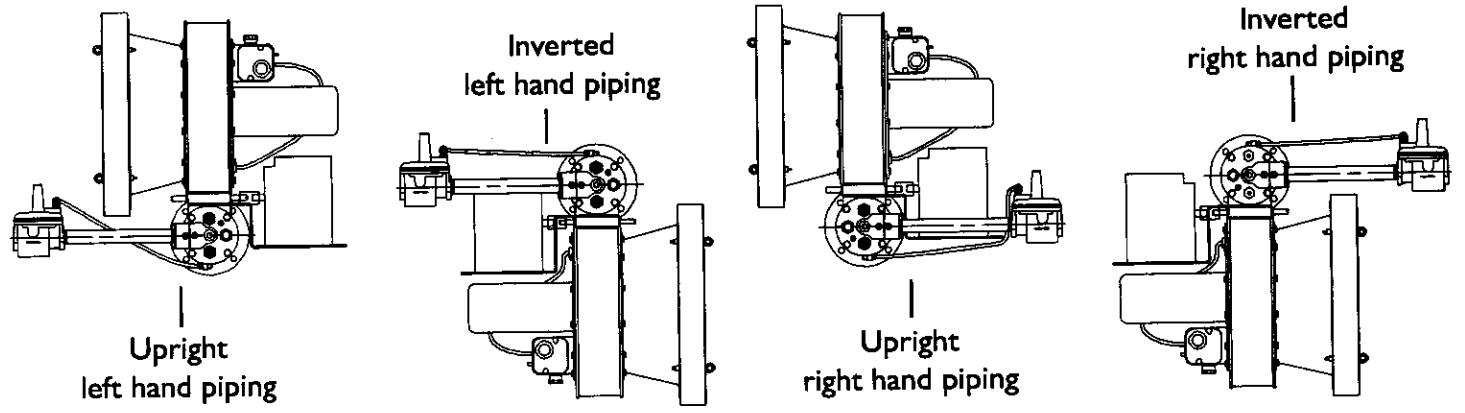



**Offered By:**

Power Equipment Company  
2011 Williamsburg Road  
Richmond, Virginia 23231  
Phone (804) 236-3800  
Fax (804) 236-3882

---

[www.peconet.com](http://www.peconet.com)